

MONKEY BUSINESS



Congrats David Liu and Tony Ho

By Alexander Lin

Co-president David Liu of Lynbrook Robotics has qualified as a finalist in the annual Intel Science Talent Search, placing him among the top 40 participants in the country. Earning \$7,500, David and Raman Nelakanti were honored in a special surprise assembly. David and Raman were chosen from among the six semifinalists, including robotics member Tony Ho, from Lynbrook.

The Intel Science Talent Search represents the culmination of a research project that may span several years. This year, Lynbrook produced the highest number of semi-finalists and finalists from all the public high schools in the country.

David's project is a program used to recognize and differentiate images based on properties such as color composition and specific textures.

Lynbrook Robotics would like to congratulate these students for their amazing accomplishments. Good job David!

this issue

- P.1 Build Season FRC 2010
- P.2 Bringing Objects to Life
- P.3 Personal Voice:
Robotics in College
- P.4 Spreading Robotics to the
World



FIRST Robotics Competition 2010

By Haochuan Ni

The 2010 FRC competition season has arrived. For some, it will be the first time that they've been to a FRC regional or even traveled away from home without parents. For others, it will be a time to relive the excitement and triumph of previous years.

This year, we will be competing at the San Diego Regional competition and the Silicon Val-

ley Regional competition. Many members burned the midnight oil to complete the machine of metal, plastic, and semiconductors. A picture of the machine is on page 3.

It was a fast and intense season, but in the end, our effort is worth it. It's time to breakaway for competition.

Go Funky Monkeys!



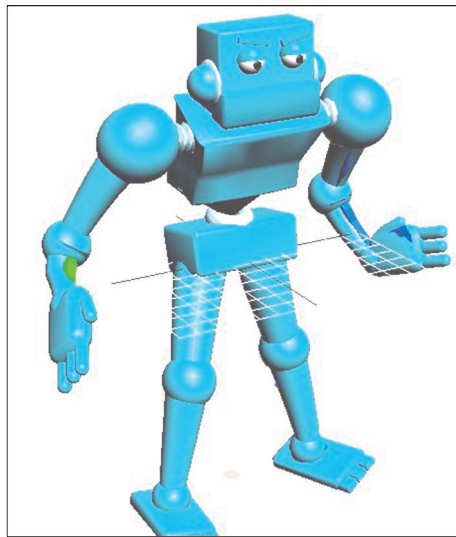

Bringing Objects to Life

Action figures get hammered for the sake of safety

LEFT: Jake's character model. The animation team fused the biped template with a customized character model, retaining the functions of biped.

By Haochuan Ni

Jake doesn't know how to hold a wrench, operate a drill press, or lift a robot properly.

Instead, he is another ignorant student waiting to be the victim of various dangers lurking around a robotics workshop. Readers (or viewers) can take cold comfort in the fact that Jake isn't a squishy organic life form. He's an animated character who injures himself to teach us the various safety precautions that we should take when working. Jake, along with his buddy Simon, was featured in our FIRST animation submission this year.

FIRST holds an annual animation competition that runs from October to December. These safety-themed animations are specifically aimed to increase awareness of the importance of safety in robotics.

This year, the team's animation revolved around two buddies, Jake and Simon, in a workshop. "Jake is harsh and irrational," said Annie Yang, the leader of the animation project, "while Simon is nerdy and, to Jake's chagrin, always right."

This seemingly simple 40 second animation was actually the result of a hardworking team of members.

"We really jumped into the project thinking we could do anything," commented Annie, "It was definitely that mindset that allowed us make such a complex animation."

The animation was also a significant leap in the team's proficiency in using 3ds Max, the animation software. Among the greatest advancement is the design and animation of the character models. These more advanced models allow Jake and Simon to express actual personality.

"By using a biped skeleton template, we produced realistic-looking model movement that was visually superior to previous character models," said Yusuke Sato, a senior member who

worked on the character models.

Despite the advancement in technical choreography, the animation project suffered several delays, mainly due to the difficulty perfecting the character models.

"The biped functionality was very temperamental in doing what we wanted it to do," said senior member Abhinav Sinha, "We were forced to use several work-arounds in order to combine our work into one master slide."

However, despite the difficulties, the animation team's new techniques and knowledge would be a boon to future animations.

"I think that this year was a very good year to build up experience," Abhinav noted, "The members in the group really learned how to use the software effectively, and I think this will give us a great advantage when we start with next year's animation."

"Hi, I'm Jake, and I'm here to show you why safety's for dweebs..."

BOTTOM: The "sprinkling" effect is one of the new innovations in this year's animation. Here, Simon sprinkles basic baking soda to neutralize the battery acid.

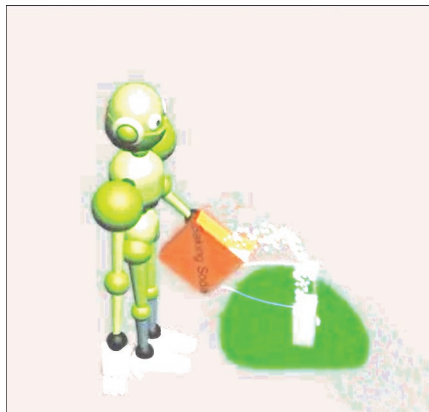

Fleet Week

Weekend of the Blues

By Haochuan Ni

F/A-18 Hornets howled past the audience as the United States Navy's Blue Angel flight demonstration team performed knife-edge passes over San Francisco's annual Fleet Week.

Fleet Week is an international demonstration held in various coastal cities to showcase military hardware ranging from guided missile destroyer warships to flight teams.

The highlight of the show was the US Navy Blue Angels. Considered to be one of the finest flight demonstration teams in the world, the Blue Angels can maintain a flawless flight formation during rolls with wingtips only 18 inches apart.

At this event, members of Lynbrook Robotics man the merchandise booths. Many members of the audience who were awestruck by the impressive performances of the pilots, especially young children, bought model airplanes and t-shirts as souvenirs from our booth. This year, the overcast and cold weather prevented some people from attending this event. However, through the hard work of the participants, the team raised a total of \$1264 from the merchandise.

The fundraiser was an intense event, with members standing at merchandise booths for many hours. Despite the hard work, participants had a lot of fun watching state-of-the-art military and aerobatic hardware soaring through the air.



The CalGames Lunacy Replayed

By Haochuan Ni

WOODSIDE HIGH SCHOOL — The buzzer sounds as robots accelerate from their launch pad and start performing. A second buzzer rings as drivers feverishly rush towards the controls. This intensity marks the first taste of competition for members in this school year.

The CalGames is an off-season event organized by Western Regional Robotics Forum. Every year, local Bay Area teams participate in this competition to replay the previous FRC season-- in this case FRC 2009's Lunacy.

Despite not winning any awards, many new members were intrigued upon seeing an actual match which was unlike a generic overhead view found in many competition archives.

"I think CalGames is a significant event in that it allowed new members to gain an insight to what a FIRST robotics competition would look like," acknowledged team co-president Toshitaka Tachibana, "Being at an actual competition is very different from seeing it on a screen, as it removes that sense of detachment. It also allows them to look at the design and mechanics that our team and local teams put into the robots."

Robotics in College

Robotics Experiences Carry on to College

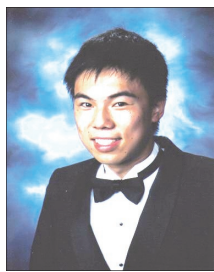

RIGHT: Johnathan Chai's small robot to "simulate the behavior of bacteria flagella. The robot was built using Lego parts, servo motors, an Arduino controller, and a breadboard with components."

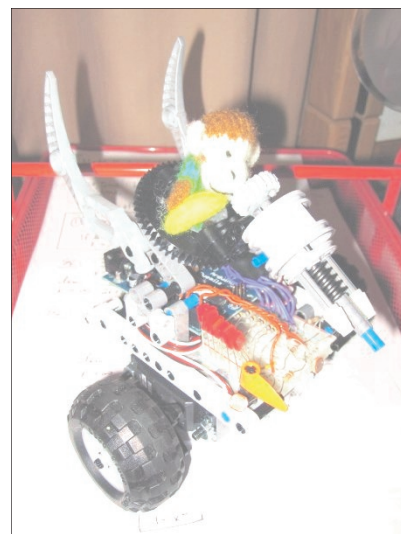

Johnathan Chai — former co-president, Lynbrook '09

During my first semester at Harvey Mudd College, I have found good use for the knowledge gained from participating on the Lynbrook FIRST Robotics Team. Mudd is an engineering focused liberal arts school in Southern California, so it was not a surprise that I would find opportunities for my nerdy side to explore.

After FIRST founder Dean Kamen spoke as Mudd's commencement last spring, an enthusiastic professor and several students assembled together to help mentor a local team at Diamond Bar High School. We held a workshop using KNEX to prepare the rookies for the FRC build season. Unfortunately, the team dropped out from the competition due to their head teacher's leave of absence. Nonetheless, the ambitious Diamond Bar students hope to try again next year. Our group at Mudd also plans to organize a pre-ship scrimmage in our cam-

pus gym for surrounding teams.

For my "BioComp 6" (biology and computer science hybrid) course's final project, I had to create a small robot to simulate the behavior of bacteria flagella. I utilized components that are a common sight on a FRC robot. My machine was built using Lego parts, servo motors, an Arduino speed controller, and a breadboard with components. I wrote an autonomous routine in the Python language that enabled the robot to seek out light using three photoresistors. The tricks I learned while competing in Botball made constructing the Lego structure an easy task. Stripping and neatly organizing wires for the electronics were other useful skills I picked up from building a FIRST robot. The monkey-manned laser beam on a turret ensured that this robot dominated our fellow robotic bacteria!

The Robot - SoccerChimpBotExtreme

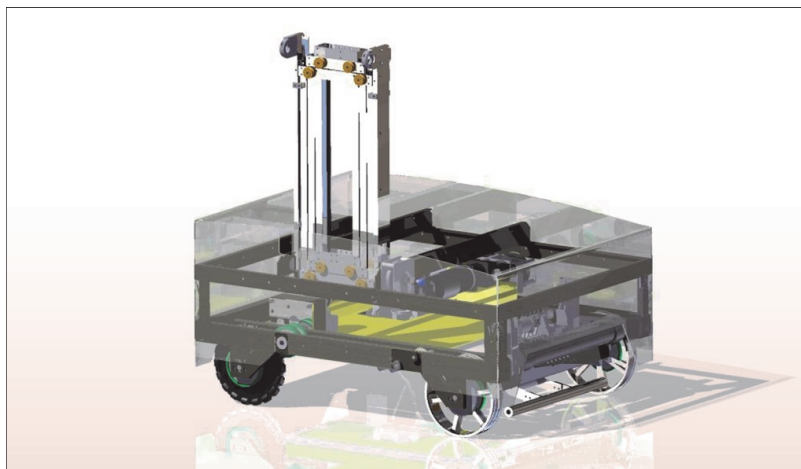

This machine of metal, plastic, and semiconductors is a fast and versatile robot with a multi-stage lift that has the ability to elevate the robot on any piece of sturdy metal bar up to seven feet high. A strong kicker and controlling roller makes this machine a potent soccer player.

Upcoming Events

Robot Shipping Date

— February 23

San Diego Regional

— March 4 - 6

Silicon Valley Regional

— March 18 - 20

Reaching Out to our Community

Spreading robotics

Honorary Officer Alric Siu explains the 2008 FRC game of Overdrive to members of Jamaican FLL team.



By Alric Siu

The Funky Monkeys hosted a demonstration to a visiting FIRST Lego League (FLL) team from Jamaica. The team, called the LegoYuhMindJrs, came to participate in the 2009 NorCal FLL Championship in Newark, California.

The FLL is a competition targeted at elementary and middle school students, and a precursor to the high school level FIRST Robotics Competition. These students use Lego Mindstorm Robotics Kits to design, build and program robots that autonomously complete missions modeled after challenges facing today's scientists. Although teams are limited to using only Lego parts, three motors, and three different sensors, they are still able to create robust contraptions capable of completing all the missions autonomously.

LegoYuhMindJrs started out as an afterschool workshop in Jamaica led by their

team mentor, Marvin Hall. The workshop continued as courses for summer camps, after which it grew into community outreach projects and finally into the only team participating in FLL competitions in their country.

Four members of LegoYuhMindJrs took part in our demonstration. We gave our visitors a chance to drive robots from previous years. The team was elated about the event, as they have never seen nor driven a 120 pound robot.

Although the members of the FLL team are still a few years shy from the age requirements of FRC, LegoYuhMindsJrs will continue to expand their technological horizon and will be preparing to participate in FRC competitions. Even though their team will face challenges in initiating a FRC team, the Funky Monkeys will certainly be glad to lend a helping hand in the near future.



Lynbrook Robotics

1280 Johnson Ave.
San Jose, CA 95129
info@lynbrookrobotics.com
www.lynbrookrobotics.com